

GEZE Perlan AUT-NT

GB Wiring diagram

Table of contents



1	Symbols and means of representation	3
1.1	Warnings	3
1.2	Further symbols and means of representation.....	3
2	Validity.....	3
3	Product liability	3
4	Notes	3
4.1	Important safety instructions	3
4.2	Mounting instructions.....	4
4.3	Safety-conscious working	4
4.4	Checking the mounted system	4
4.5	Disposing of the door system.....	4
5	Abbreviations.....	5
6	Supply terminals	5
7	Function description	5
8	Mounting of the components.....	6
8.1	Requirement.....	7
8.2	Mounting the flush-mounted controller and power pack.....	7
9	Contactors.....	10
9.1	Radar movement detector GC 302 R.....	10
9.2	Switch (floating contact).....	11
9.3	Radio control	12
10	Contactor close.....	12
10.1	Switch (floating contact).....	12
10.2	Radio control	12
11	Push & Go	12
12	Stop	12
13	Operating mode	13
13.1	Setting the operating mode.....	13
13.2	Operating modes	13
13.3	Display of the operating mode	13
13.4	Behaviour in the individual operating modes.....	14
14	Mains connection	15
14.1	Safety instructions	15
15	Motor	15
16	Low-energy operation	15
17	Commissioning and service.....	16
17.1	Configuration	17
17.2	Steps for commissioning	18
18	Error display	19

1 Symbols and means of representation

1.1 Warnings



In these instructions, warnings are used to warn against material damage and injuries.

- ▶ Always read and observe these warnings.
- ▶ Observe all the measures that are marked with the warning symbol and warning word.

Warning symbol	Warning word	Meaning
	DANGER	Danger for persons. Non-compliance will result in death or serious injuries.
	WARNING	Danger for persons. Non-compliance can result in death or serious injuries.
	CAUTION	Danger for persons. Non-compliance can result in minor injuries.
–	CAUTION	Information on avoiding material damage, understanding a concept or optimising the processes.

1.2 Further symbols and means of representation

Important information and technical notes are emphasised in order to illustrate the correct operation.

Symbol	Meaning
	means "important note"
	means "additional information"
	Symbol for an action: Here you have to do something. ▶ Observe the sequence if there are several action steps.

2 Validity

Valid for units from:

- Hardware: Perlan AUT-NT, Rev. F
- Software: Perlan AUT-NT, V 1.0

3 Product liability

In accordance with the liability of manufacturers for their products as defined in the German "Produkthaftungsgesetz" (Product Liability Act), the information contained in these instructions (product information and proper use, misuse, product performance, product maintenance, obligations to provide information and instructions) is to be observed. Non-compliance releases the manufacturer from its statutory liability.

4 Notes

4.1 Important safety instructions

To ensure personal safety, it is important to follow these instructions.

Keep these instructions.

- Only qualified personnel who are authorised by GEZE may carry out mounting, commissioning and maintenance.
- GEZE shall not be liable for injuries or damage resulting from unauthorised modification of the equipment.
- GEZE shall not be liable if products from other manufacturers are used with GEZE equipment. Use only original GEZE parts for repair and maintenance work as well.
- The connection to the power supply must be carried out by a qualified electrician in accordance with VDE 0100 Part 610.
- The electrical installation at the customer has to have an all-pole power disconnecter that can be secured reliably against reactivating (e.g. lockable switch with at least 3 mm contact opening).
- A customer-side 10 A overload cut-out must be used as the line-side disconnecting device.

- In accordance with Machinery Directive 2006/42/EC, a safety analysis must be performed and the door system identified in accordance with CE Identification Directive 93/68/EEC before the door system is commissioned.
- ▶ Enter the classification in accordance with DIN 18650-1 on the information plate and adhere the information plate onto the drive housing so that it is visible from below.
- ▶ Observe the latest versions of guidelines, standards and country-specific regulations, in particular:
 - BGR 232 "Guidelines for power-operated windows, doors and gates"
 - DIN 18650, Part 1 and Part 2 "Automatic door systems"
 - DIN VDE 100-600 "Installation of low-voltage systems - Part 6 Tests"
 - DIN EN 60335-1 "Safety of electrical devices for home use and similar purposes"
 - Accident-prevention regulations, especially BGV A1 (VBG1) "General regulations", BGV A3 (VBG4) "Electrical systems and equipment"

4.2 Mounting instructions



- ▶ Observe the maximum permissible total current draw at the power pack for the drive unit for powering the peripherals (max. 50 mA).

The sliding door drive is designed solely for use in dry rooms.

- ▶ Use only cables specified in the cable plan.
- ▶ Always use insulated wire-end ferrules for wire cores.
- ▶ Insulate unused wires.
- ▶ Secure loose, internal drive cables with cable ties.

4.3 Safety-conscious working



DANGER!

Danger of death from electric shock!

- ▶ Before working on the electrical system, interrupt the power supply (mains) and check the safe isolation from supply. Note that the system will still be supplied with power, despite the fact that the power supply is disconnected, if an uninterruptible power supply (UPS) is used.
- ▶ Secure the workplace against unauthorised entry.
- ▶ Take the swinging area of long system parts into account.
 - Risk of injury when a sliding door drive is opened through moving parts (drawing in of hair, clothing ...).
 - Risk of injury by crushing, impact, shearing or drawing-in spots.
 - Danger of injury by sharp edges in the sliding door drive.
 - Risk of injury through breakage of glass.

4.4 Checking the mounted system

- ▶ Check the measures for securing and avoiding trapping, knocking, shearing and hair etc. being drawn in.
- ▶ Check the function of the contactors.

4.5 Disposing of the door system

The sliding door drive consists of materials that should be recycled.

The individual components have to be sorted in accordance with their material type:

- Metal (carrier plate, hanger bolt, ...)
- Aluminium (track, cover, ...)
- Plastic (roller carriage, ...)
- Electronic components (controller, switch, ...)
- Cables

The parts can be disposed of at the local recycling station or a scrap processing company.

5 Abbreviations

Wire colours

BN	brown	GN	green	OG	orange	TQ	turquoise
BK	black	GY	grey	PK	pink	VT	violet
BU	blue	YE	yellow	RD	red	WH	white

Connections, terminals and plugs

GND	Reference potential	MA	Motor
INC	Rotary transducer	MB	Motor
K	Contact	STOP	Stop
KS	Contact close		

6 Supply terminals

CAUTION!

Destruction of the component through incorrect connection.

Defective controller

- ▶ Ensure that the polarity of Connections 1 and 2 is correct.

Motor connection

Terminal	Signal name	Wire colour
1	Earth	white
85	Signal 1	yellow
86	Signal 2	green
82	+5 V	brown
MB	Motor	+ red
MA	Motor	- blue

Voltage connection

Terminal	Signal name
1	Earth (-) power pack
2	24 V DC (+) power pack

Switch connection

Terminal	Signal name
29	CLOSE
21	OPEN
15	STOP
1	Earth

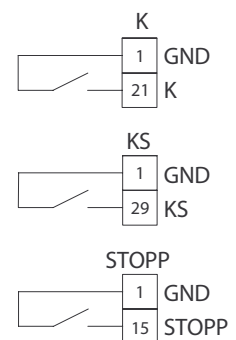
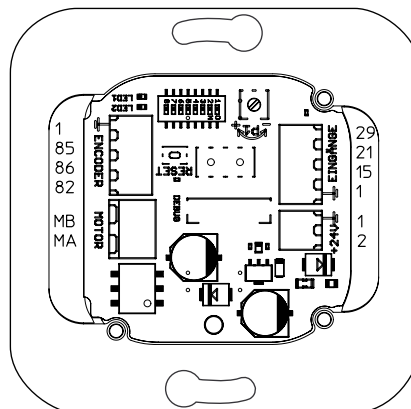

7 Function description

The system is an electrical sliding door drive. The controller drives a 24 V DC motor that moves a linear sliding door via a toothed belt.

The controller and power packs have to be mounted in separate concealed/surface-mounted boxes in accordance with DIN 49073. The housing is hidden completely in separate concealed/surface-mounted boxes. The controller is operated via a detachable switch that fits into a common switch range with a rocker switch dimension of 55 mm. The controller is supplied by a power pack. The power pack supplies 24 V direct current and is connected to Terminals 1 and 2. It can be mounted in a neighbouring concealed/surface-mounted box or further away.

The screw terminals for connecting the lines are combined into groups:

- Supply voltage (Terminals 1 and 2)
- Inputs (Terminals 1, 15, 21, 29)
- Motor (Terminals MA and MB)
- Rotary transducer (Terminals 1, 85, 86 and 82)

The hold-open time of the sliding door drive can be set via the potentiometer P1. The exact functionality of the sliding door drive can be selected by means of the DIP switch.

After correct connection and commissioning the controller is ready for use. The motor is driven by pressing the buttons OPEN and CLOSE of the switch or by electrical switching of an input (Terminals 1, 15, 21, 29).

8 Mounting of the components



Lay the conductors so that single-insulation power conductors do not cross single-insulation 24 V low voltage conductors.

If conductor crossing cannot be avoided, the individual conductors have to be insulated additionally with shrink tubing.

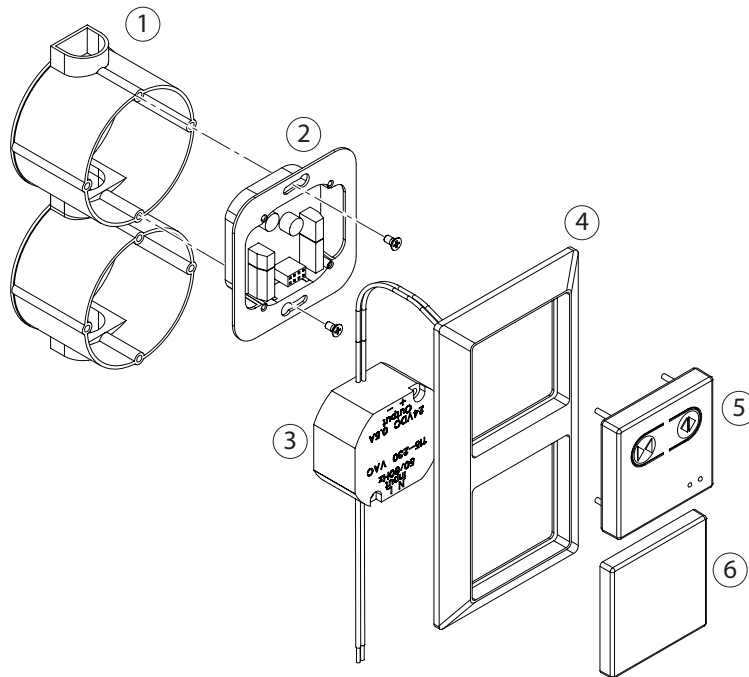

- | | | | |
|---|---|---|-------------------------|
| 1 | Flush-mounted box to DIN 49073 (provided by customer) | 5 | Switch, Mat. No. 140101 |
| 2 | Controller, Mat. No. 139993 | 6 | Cover |
| 3 | Power pack 230 V / 24 V, Mat. No. 139994 | | |
| 4 | 2-fold cover frame for vertical installation | | |



In addition to the connection displayed here, the following variants exist:

- Connection variants for controller Perlan AUT-NT
 - Controller at the door in flush-mounted box
 - Controller at the door in surface-mounted box
 - Controller installed externally (e.g. wall recess, control cabinet ...)
- Connection variants for power pack Perlan AUT-NT
 - Power pack at the door in flush-mounted box
 - Power pack at the door in surface-mounted box
 - Power pack installed externally (e.g. wall recess, control cabinet ...)

8.1 Requirement

- Cable laying to GEZE cable plan
- Mounting height for controller: from 850 mm to maximum 1200 mm above the top edge of the completed flooring

8.2 Mounting the flush-mounted controller and power pack

The instructions describe the mounting recommended by GEZE of a connection variant with flush-mounted controller and power pack.

- ▶ Lay the 24-V output cable of the power pack into the flush-mounted box (1).

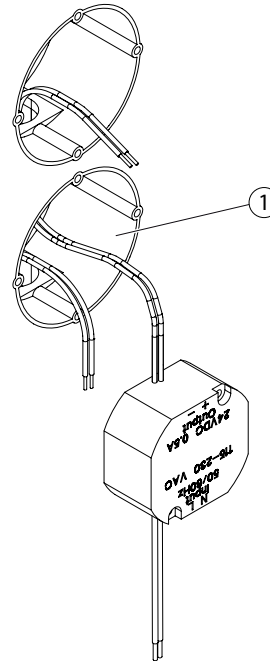

- ▶ Connect the 24-V output cable of the power pack to the controller (2) in accordance with the wiring diagram.

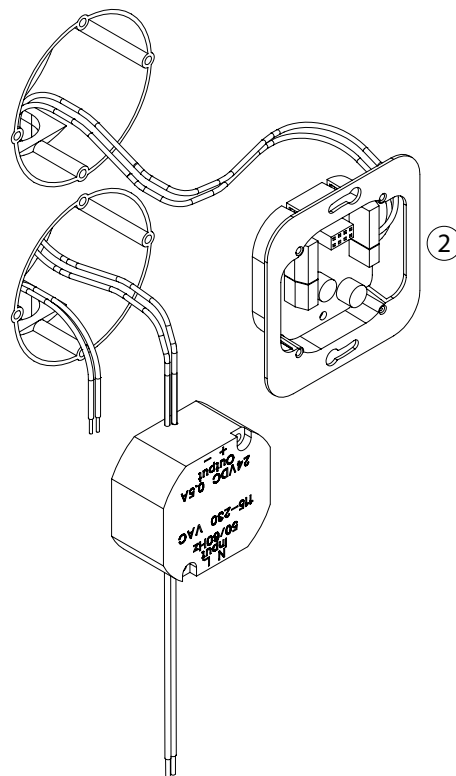

- ▶ Insert the power pack (3) into the flush-mounted box (1).

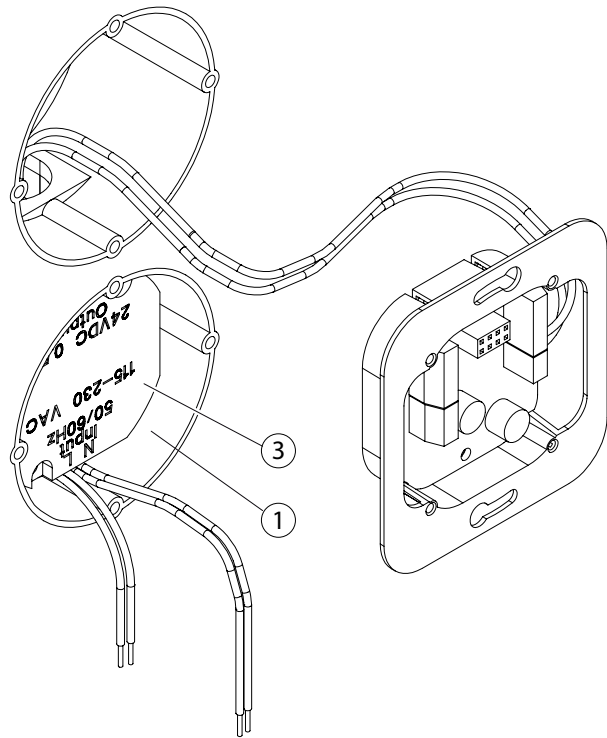

- ▶ Connect the power supply cable to the fusing terminal strip (7) of the power input line of the power pack.

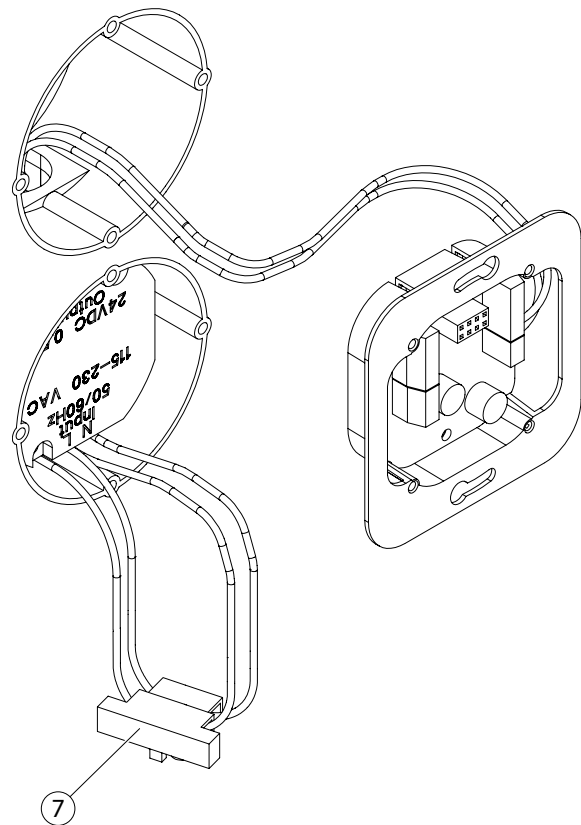

- ▶ Connect the motor connection cable to the controller (2) in accordance with the wiring diagram.

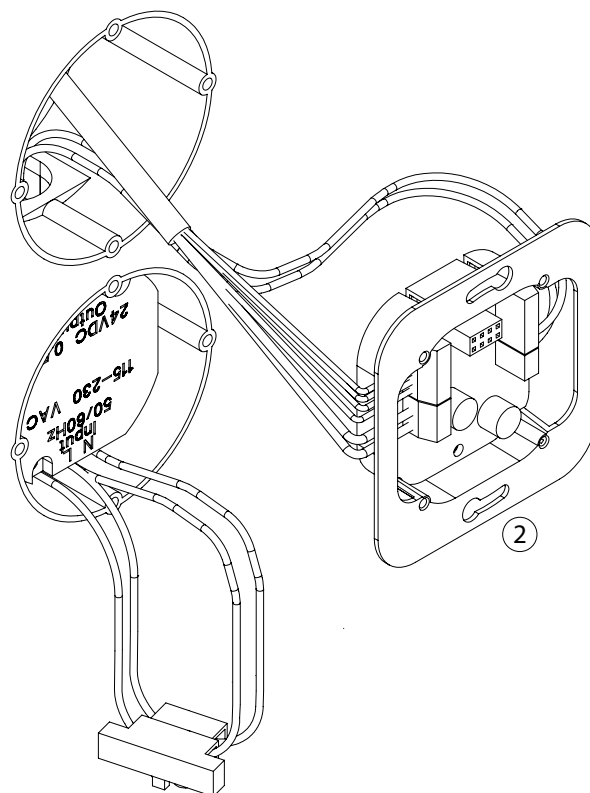

- ▶ Mount the controller (2) in the flush-mounted box (1).

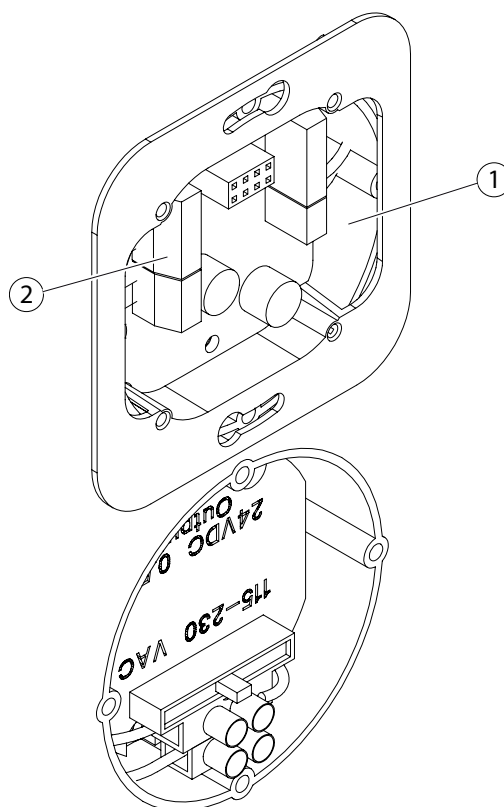

- ▶ Fasten the controller (2) in the flush-mounted box (1) with screws.
- ▶ Mount the 2-fold cover frame (4) for vertical installation.
- ▶ Mount the cover (6) onto the 2-fold cover frame (4).
- ▶ Put the switch (5) onto the controller (2).

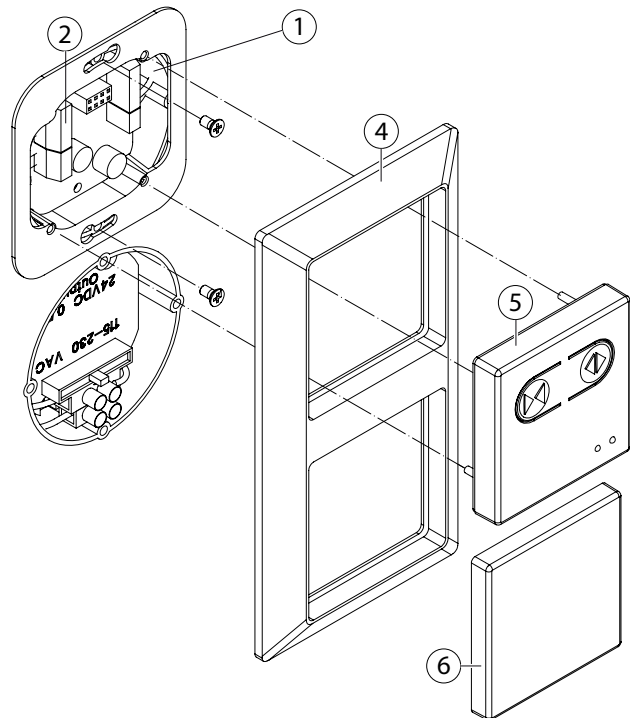

Accessories programme switches GEZE:

- Frame 1-fold, Alpine white, flush-mounted, Mat. No. 115376
- Frame 2-fold, Alpine white, flush-mounted, Mat. No. 115377
- Frame 3-fold, Alpine white, flush-mounted, Mat. No. 115378
- Cover, A5500, Mat. No. 118480

- Surface-mounted box 1-fold, Alpine white, Mat. No. 120503
- Surface-mounted box 2-fold with A5500 cover, Alpine white, Mat. No. 128609
- Surface-mounted box 3-fold with A5500 cover, Alpine white, Mat. No. 133206

9 Contactors

9.1 Radar movement detector GC 302 R



- An additional power pack 230 V / 24 V Perlan AUT-NT is required to supply external actuation elements.
- ▶ Take the maximum permissible current draw into account when an additional power pack is used (500 mA).

Wiring instructions:

- ▶ Lay the conductors so that single-insulation power conductors do not cross single-insulation 24 V low voltage conductors.
- ▶ If necessary, insulate the power and low-voltage conductors additionally with shrink tubing.
- When the contactor is actuated, the contact is closed (0 V applied to the Input 21).

- GC 302 R black, Mat. No. 124087
- GC 302 R as per RAL, Mat. No. 124088
remote control does not work with detector hood mounted, LED not visible
- GC 302 R is a direction-sensitive radar movement detector.
- ▶ Follow mounting instructions, Mat. No. 123457.
- Accessories:
 - Remote control, Mat. No. 099575
 - Ceiling installation kit, Mat. No. 115384
 - Rain cover, Mat. No. 115339

- 1 Power supply cable 230 V / 50 Hz
Mains fuse 10 A by customer, with all-pole disconnection
- 2 Fuse terminal strip 2.5 mm²
with glass fuse 5x20 mm, T2A
- 3 Power pack 230 V / 24 V, Perlan AUT-NT, Mat. No. 139994
- 4 Conductor terminal strip, 2-pole, 1.5 mm²
- 5 Controller

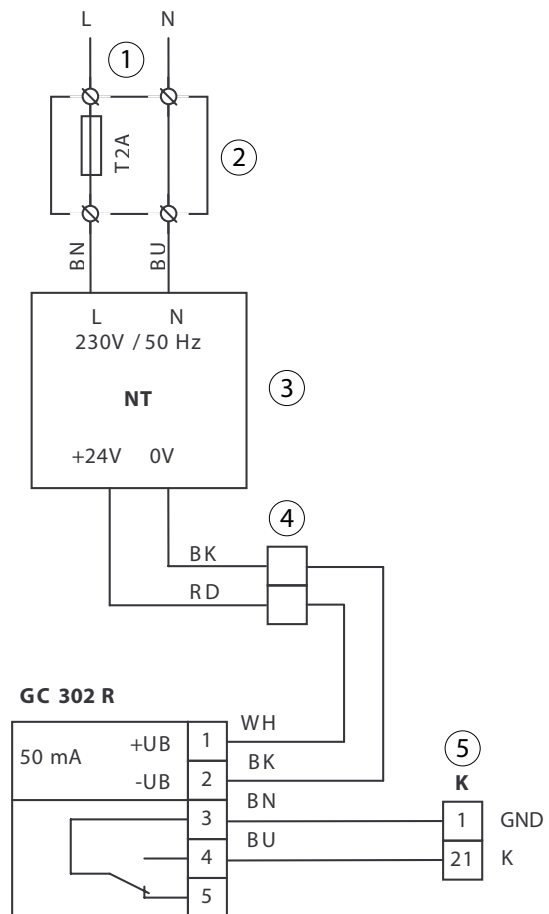

- ▶ Set the detection field and sensitivity of the radar movement detector.
- ▶ To align the detection field, turn the planar antenna and adjust its tilt angle.
- ▶ If several GC302 R units are mounted next to or after one another, set different device addresses using the two DIP switches. Otherwise, the settings of the other detectors will also be changed by the remote control.

9.2 Switch (floating contact)

- Plastic elbow switch, white, Mat. No. 114078
- Plastic elbow switch, stainless steel, Mat. No. 114077
- Accessories:
 - IP65 switching insert, Mat. No. 114156
 - Additional contact, Mat. No. 114157
 - Back panel for plastic elbow switch white, Mat. No. 131219, stainless steel, Mat. No. 131220
- Stainless steel elbow switch, Mat. No. 119898
- Stainless steel elbow switch LS990, surface-mounted, Mat. No. 128582
- Stainless steel elbow switch LS990, flush-mounted, Mat. No. 128583

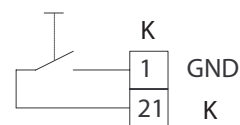

9.3 Radio control

- ▶ Observe the mounting and service instructions of the GEZE Automatic Radio Program, Mat. No. 132159.
- Radio transmitter module WTM, Mat. No. 131212
- Hand-held radio transmitter WTH-1, Mat. No. 131209
- Hand-held radio transmitter WTH-2, Mat. No. 131210
- Hand-held radio transmitter WTH-4, Mat. No. 131211
- Radio receiver module WRM-24, Mat. No. 131213

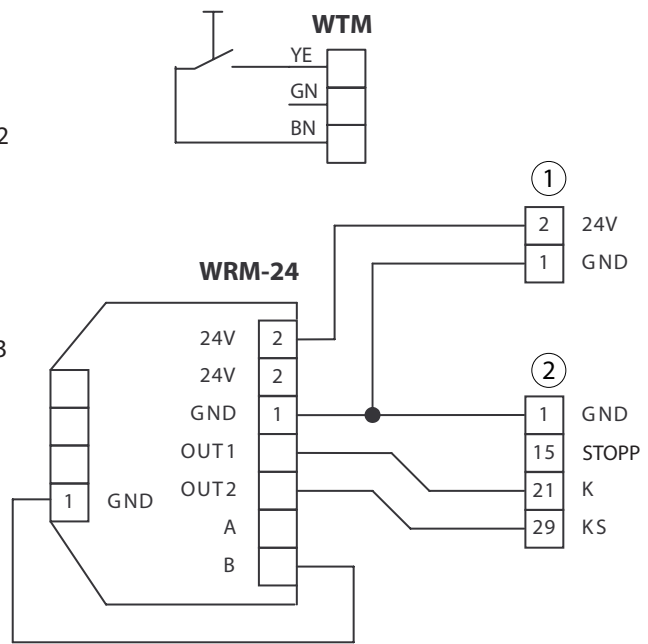

- 1 24 V output cable additional power pack
- 2 Contactor KS, K, STOP

10 Contactor close

When the Contactor close is actuated, the contact is closed (0 V applied to the Input 29).

10.1 Switch (floating contact)

See Switch contactor

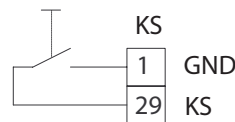

10.2 Radio control

See Radio control contactor

11 Push & Go



WARNING!
Danger of injury through crushing!

- The Push & Go function allows actuating of the sliding door drive without contactors being used.
- When the Push & Go function is set, the sliding door drive opens the door automatically as soon as the door leaf is moved manually out of the closed position.

12 Stop

- Input 15 can be used as the Stop input.
- When the contactor is actuated, the contact is closed (0 V applied to the Input 15).
- The door stops immediately as soon as the switch is activated.
- As long as the switch is activated, the door remains in its position.

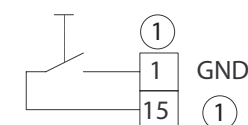

1 Stop

13 Operating mode

13.1 Setting the operating mode

The operating mode of the sliding door drive has to be set during commissioning (see Chapter 17).

13.2 Operating modes

Dead-man

The drive continues to move in the direction as long as its button is pressed or the signal is applied. In case of obstacles the sliding door drive stops.

Semi-automatic

The drive moves in the direction of the pressed button or of the applied signal. The drive does not close automatically after an opening pulse. It remains in the open position and only closes after a renewed closing command. The sliding door drive stops in case of obstacles, a stop signal or control commands against the current direction of movement.

Automatic

In addition to the semi-automatic operating mode the sliding door drive closes automatically after the set hold-open time.

In the case of obstacles in the closing direction the door opens again and closes automatically after the set hold-open time. In the case of control commands against the current direction of movement the sliding door drive reverses. At a stop signal the sliding door drive stops for the duration of the stop signal. When the stop signal drops again, the door moves further in the direction of movement previously selected.

Single permanent opening

In order to induce a unique permanent opening in automatic mode the OPEN and CLOSE buttons have to be kept pressed for longer than 2 seconds. The sliding door drive does not close automatically after this opening pulse. It remains in the open position and only closes after a renewed closing command (press CLOSE button). After the close command the sliding door drive is back in automatic mode.

13.3 Display of the operating mode

The operating mode is indicated by the green LED at the operating panel. During an automatic cycle it lights up continuously as long as the sliding door drive is moving. During the hold-open time the LED flashes. In semi-automatic mode the LED flashes during the movement.

The red LED flashes rapidly in case of a fault (system fault).

Clearing a system fault:

- ▶ Press the Reset button for at least 2 seconds.

13.4 Behaviour in the individual operating modes

Automatic

	OPEN button ¹⁾	CLOSE button	STOP button ²⁾	Obstacle
Closed	Open, wait for hold-open time, close	---	Door remains closed, inactive until stop button. An OPEN button actuation remains stored for 20 s. If the stop button becomes inactive within this period, opening is carried out	---
Opens	Opens further, wait for hold-open time, close	Reverses and closes	Door stops, hold-open time is set. If the STOP button becomes inactive within the hold-open time, the door opens further, otherwise the door closes.	Door stops, waits briefly, tries to open further (max. 3x). If opening is not possible, the door closes
Open	Hold-open time is set again	Hold-open time is aborted, closes	Door remains open, hold-open time is set again, as long as the button is active.	---
Closes	Reverses, opens, wait for hold-open time, close	Closes further	Door stops, if STOP button becomes inactive, the door closes	Reverses, opens, wait for hold-open time, close
Starting of the hold-open time if the door is open and the OPEN button inactive				

¹⁾ possibly additional Close actuation sensors at the same terminal

²⁾ higher priority than OPEN button and CLOSE button



The Push & Go function behaves like the OPEN button.

If the OPEN and CLOSE buttons are pressed simultaneously:

- Less than 2 s: No reaction
- More than 2 s: Door opens or remains open (permanently open function) Aborting by pressing the CLOSE button

Semi-automatic

	OPEN button	CLOSE button	STOP button ¹⁾	Obstacle
Closed	open	Remains closed	Remains closed	–
Opens	Opens further	Stops	Stops	Stops
Open	Remains open	Close	Remains open	–
Closes	Stops	Closes further	Stops	Stops
Stand still between open and closed	Opens	Closes	Stops	–

¹⁾ higher priority than OPEN button and CLOSE button



- The Push & Go function behaves like the OPEN button.
- If the OPEN and CLOSE buttons are pressed simultaneously, there is no reaction.

14 Mains connection

14.1 Safety instructions



DANGER!
Danger of death from electric shock!

- ▶ Have the direct connection of the sliding door drive to the mains voltage carried out only by a qualified electrician.
- ▶ In the case of a power connection carry out a test of the power connection in accordance with VDE 0100 Part 610.



Lay the conductors so that single-insulation power conductors do not cross single-insulation 24 V low voltage conductors.

- ▶ If necessary, insulate the power and low-voltage conductors additionally with shrink tubing.

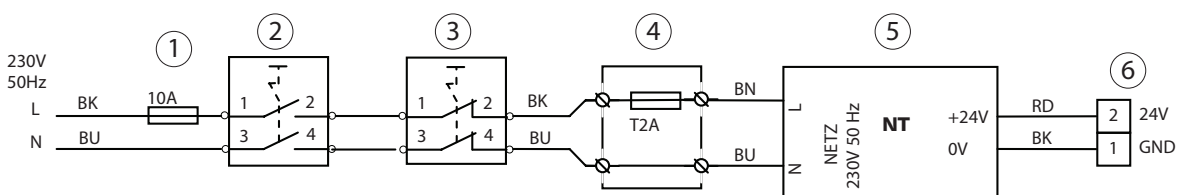

- 1 Mains fuse (provided by customer)
- 2 Master switch (provided by customer)
- 3 Emergency-off (optional)
- 4 Fuse terminal strip 2.5 mm² with glass fuse 5x0 mm T2A
- 5 Power pack 230 V / 24 V Perlan AUT-NT, Mat. No. 139994
- 6 Controller NT

15 Motor

Motor-gearing unit, Mat. No. 139992

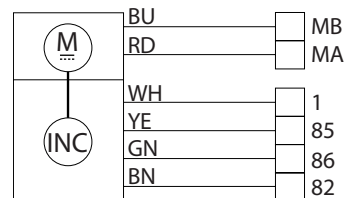

16 Low-energy operation

Low-energy doors are as a rule not equipped with additional protective devices, since the kinetic energy values are viewed as harmless.

DIN 18650-2, 4.4.4 defines the requirements for low-energy operation:

- The hold-open time has to exceed 5 s.
- The static force during opening and closing has to amount to less than 67 N, measured 25 mm away from the main closing edge and vertically to the main closing edge.
- The kinetic energy of the door has to amount to less than 1.6 J at every movement point.
- In the case of a power failure it must be possible to open the door completely with a maximum of 67 N measured vertically to the main closing edge.

17 Commissioning and service

The following sections describe the parts of the controller which are required for commissioning, the functions which have to be set and how to carry out the commissioning step-by-step.

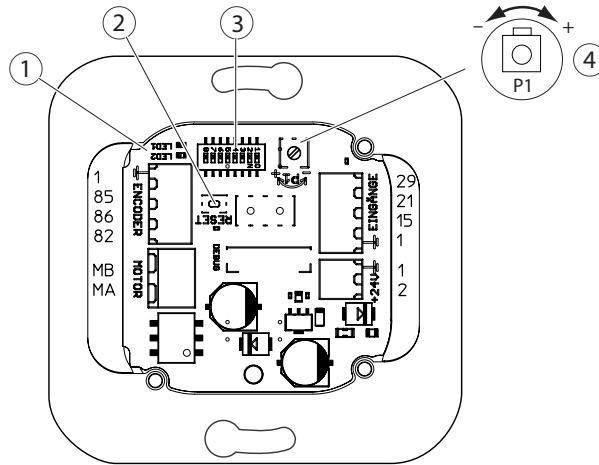

- 1 LEDs for status display
- 2 Reset button

- 3 DIP switch for configuration
- 4 Potentiometer for hold-open time

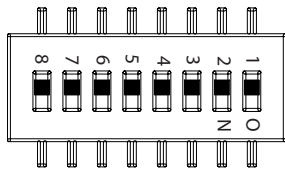

DIP switch	Description	OFF	ON
1	Function	Semi-automatic	Automatic
2	Dead-man	Deactivated	Activated
3	Push & Go	Deactivated	Activated
4	Behaviour at an obstacle *	Reversing	Stop and stay
5	Closing speed	Halved	Full
6	Speed 70%, Leaf weight 80 kg–60 kg	Deactivated	Activated
7	Speed 85%, Leaf weight 60 kg–40 kg	Deactivated	Activated
8	Speed 100%, Leaf weight 40 kg–20 kg	Deactivated	Activated

- Function Semi-automatic/Automatic (1)
If the "Semi-automatic" function is activated, the sliding door drive does not close automatically. The set hold-open time at Potentiometer 1 is ignored.
If the Automatic mode is active, the sliding door drive closes after the set hold-open time.
 - Dead-man (2)
If dead-man mode is activated, the sliding door drive moves as long as the operating button is pressed. The setting of Switch 1 is ignored.
If Dead-man mode is deactivated, the sliding door drives moves after a pulse in the desired direction until an obstacle or the end of the system is recognised.
 - Push & Go (3)
If Push & Go is activated, the sliding door drive starts moving automatically when it is pushed.
 - Behaviour at an obstacle (4)
If the "Reverse" function is activated, the drive moves in the opposite direction when an obstacle is recognised during closing, and stops when an obstacle is recognised during opening. Moving during reversing is always carried out at reduced speed.
If the "Stop and stay" function is activated, the drive stops when an obstacle is recognised both during opening and closing.



- *) Behaviour at an obstacle (4) (only in closing direction):
- ON setting (Stop and stay) is only possible at Semi-automatic
 - At Automatic mode the drive always reverses

- Closing speed (5)
At halved closing speed (OFF) the sliding door drive closes with half speed. At full closing speed (ON) the sliding door drive closes with full speed.

- Speed (6 to 8)
The speed has to be set on the basis of the leaf weight.
 - (6) Leaf weight 80 kg–60 kg (approx. 70% of the maximum speed) 0.20 m/s
 - (7) Leaf weight 60 kg–40 kg (approx. 85% of the maximum speed) 0.23 m/s
 - (8) Leaf weight 40 kg–20 kg (approx. 100% of the maximum speed) 0.28 m/s
 - If no or several switches are activated for the speed, moving is only carried out at the reduced speed (approx. 20% of the maximum speed).

Hold-open time

In automatic mode the hold-open time defines how long the sliding door drive waits after an open command until it closes automatically.

If the potentiometer is positioned at the right-hand stop, the hold-open time amounts to 30 seconds.

If the potentiometer is positioned at the left-hand stop, the hold-open time amounts to 5 seconds.

17.1 Configuration

The controller is configured at Potentiometer P1 as well as at the DIP switches. The function of the individual elements is explained below.



The controller does not accept the settings of the configuration until after the change into configuration mode and subsequent exiting of the configuration mode.

Configuring before the first commissioning

- ▶ Set the desired configuration in a deenergized state.
- ▶ Carry out commissioning (see Chapter 17).

The set configuration is accepted during commissioning.

Configuring during operation

- Controller is already ready. First commissioning has been carried out.
- Power supply connected, no LED lights up.

- ▶ Press the Reset button for approx. 2 seconds.

The red LED begins to flash continuously.

- ▶ Set the desired configuration.
- ▶ Press the Reset button briefly (less than half a second).

Controller is already in the starting state:

The red LED flashes twice consecutively with approx. 1.5 seconds break continuously.

- ▶ Carry out a movement.

Sliding door drive moves in creep mode.

The red LED extinguishes.

The new configuration has been accepted.

17.2 Steps for commissioning



CAUTION!

Danger of injury from moving door leaves.

The door leaves move during commissioning.

- ▶ Leave the danger area.

Preparing the controller

- ▶ Carry out the electrical connections (see Chapter 6).
- ▶ Set the configuration (see Chapter 17.1).

Carrying out a reset

- ▶ Connect the controller to the power supply and operate it.

Controller in the state of delivery or after power disconnection:

The red LED flashes twice consecutively with approx. 1.5 seconds break continuously.



- ▶ Press the Reset button for 2 seconds.

The red LED begins to flash continuously:



Checking the direction of movement:

- ▶ Open with the OPEN button and close with the CLOSE button.

If the direction of movement is wrong:

- ▶ Swap the motor cables, check the direction of movement again.
- ▶ Press the Reset button again for approx. 2 seconds.

The red LED lights up permanently, the yellow LED lights up at motor activity.



The sliding door drive moves to the closed position.

The sliding door drive moves to the opened position, first rapidly, then slowly.

The sliding door drive moves to the closed position.

The LEDs extinguish.

Checking the function

- ▶ Check the desired function.
- ▶ In case of a malfunction check the electrical connections and configuration.
- ▶ If necessary, repeat commissioning.

If the function is fault- and error-free, commissioning has been completed.

18 Error display

If the safety functions recognize a fault, the controller changes to the fault state. In this case the driver block and the safety relay are deactivated first.

The following system states have been defined for the fault recognition:

Fault code	Name	Description	Fault elimination
0	System OK	No fault	
1	Unknown fault	Unknown cause of fault	▶ Switch mains voltage off/on.
2	Self-test – several faults	The self-test has recognised several faults	▶ Carry out a reset as described in Section 17.2. ▶ Replace the controller if necessary.
4	Self-test – oscillator fault	The self-test has recognised a defective oscillator	▶ Replace the controller.
5	Self-test – relay defective	The self-test has recognised a defective relay	
6	Self-test – driver defective	The self-test has recognised a defective driver	
7	Self-test – current measurement defective	The current measurement does not function properly	▶ Switch mains voltage off/on. ▶ Carry out a reset as described in Chapter 17.2. ▶ Replace the motor and/or controller if necessary.
8	Self-test – driver fault recognition defective	The power driver no longer outputs a fault message	
9	Hardware – encoder fault	The encoder is not connected correctly or is defective	▶ Check the encoder connection. ▶ Replace the motor or controller.
10	Hardware – voltage impossible	The supply voltage lies outside the permissible range	▶ Replace the power pack. ▶ Replace the controller if necessary.
11	Memory – RAM defective	A defect has been recognised in the RAM	▶ Replace the controller.
12	Memory – ROM defective	The programme memory has been changed or is defective	
13	Memory – EEPROM defective	The data memory is defective	

A fault state is indicated by flashing codes of the two LEDs on the controller: First the red LED flashes rapidly, then it lights up continuously for approx. 20 seconds. During these 20 seconds the green LED flashes in accordance with the fault code x times. The cycle repeats until the user resets the fault.

Example: Green LED flashes 4 times, i.e. Fault code 4. This corresponds to a defective oscillator.

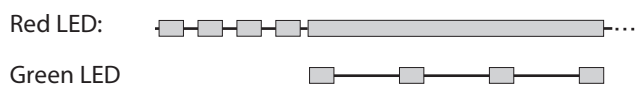

Germany

GEZE Sonderkonstruktionen GmbH
Planken 1
97944 Boxberg-Schweigern
Tel. +49 (0) 7930-9294-0
Fax +49 (0) 7930-9294-10
E-Mail: sk.de@geze.com

Germany

GEZE GmbH
Niederlassung Nord/Ost
Bühningstraße 8
13086 Berlin (Weissensee)
Tel. +49 (0) 30-47 89 90-0
Fax +49 (0) 30-47 89 90-17
E-Mail: berlin.de@geze.com

Germany

GEZE GmbH
Niederlassung West
Nordsternstraße 65
45329 Essen
Tel. +49 (0) 201-83082-0
Fax +49 (0) 201-83082-20
E-Mail: essen.de@geze.com

Germany

GEZE GmbH
Niederlassung Mitte
Adenauerallee 2
61440 Oberursel (b. Frankfurt)
Tel. +49 (0) 6171-63610-0
Fax +49 (0) 6171-63610-1
E-Mail: frankfurt.de@geze.com

Germany

GEZE GmbH
Niederlassung Süd
Reinhold-Vöster-Straße 21-29
71229 Leonberg
Tel. +49 (0) 7152-203-594
Fax +49 (0) 7152-203-438
E-Mail: leonberg.de@geze.com

Germany

GEZE Service GmbH
Reinhold-Vöster-Straße 25
71229 Leonberg
Tel. +49 (0) 7152-9233-0
Fax +49 (0) 7152-9233-60
E-Mail: service-info.de@geze.com

Germany

GEZE Service GmbH
Niederlassung Berlin
Bühningstraße 8
13086 Berlin (Weissensee)
Tel. +49 (0) 30-470217-30
Fax +49 (0) 30-470217-33
E-Mail: service-info.de@geze.com

Austria

GEZE Austria GmbH
Wiener Bundesstrasse 85
5300 Hallwang b. Salzburg
Tel. +43-(0)662-663142
Fax +43-(0)662-663142-15
E-Mail: austria.at@geze.com

Baltic States

GEZE GmbH Baltic States office
Dzelzavas iela 120 S
1021 Riga
Tel. +371 (0) 67 89 60 35
Fax +371 (0) 67 89 60 36
E-Mail: office-latvia@geze.com

GEZE GmbH

P.O.Box 1363
Reinhold-Vöster-Straße 21-29
71229 Leonberg
Germany

Benelux

GEZE Benelux B.V.
Leemkuil 1
Industrieterrein Kapelbeemd
5626 EA Eindhoven
Tel. +31-(0)40-26290-80
Fax +31-(0)40-26 290-85
E-Mail: benelux.nl@geze.com

Bulgaria

GEZE Bulgaria - Trade
Representative Office
61 Pirinski Prohod, entrance „B“,
4th floor, office 5,
1680 Sofia
Tel. +359 (0) 24 70 43 73
Fax +359 (0) 24 70 62 62
E-Mail: office-bulgaria@geze.com

China

GEZE Industries (Tianjin) Co., Ltd.
Shuangchunzhong Road
Beichen Economic Development
Area (BEDA)
Tianjin 300400, P.R. China
Tel. +86(0)22-26973995-0
Fax +86(0)22-26972702
E-Mail: Sales-info@geze.com.cn

China

GEZE Industries (Tianjin) Co., Ltd.
Branch Office Shanghai
Unit 25N, Cross Region Plaza
No. 899, Ling Ling Road,
XuHui District
200030 Shanghai, P.R. China
Tel. +86 (0)21-523 40 960
Fax +86 (0)21-644 72 007
E-Mail: chinasales@geze.com.cn

China

GEZE Industries (Tianjin) Co., Ltd.
Branch Office Guangzhou
Room 17C3
Everbright Bank Building, No.689
Tian He Bei Road
510630 Guangzhou, P.R. China
Tel. +86(0)20-38731842
Fax +86(0)20-38731834
E-Mail: chinasales@geze.com.cn

China

GEZE Industries (Tianjin) Co., Ltd.
Branch Office Beijing
Room 1001, Tower D
Sanlitun SOHO
No. 8, Gongti North Road,
Chaoyang District,
100027 Beijing, P.R.China
Tel. +86-(0)10-5935 9300
Fax +86-(0)10-5935 9322
E-Mail: chinasales@geze.com.cn

China

GEZE Industries (Tianjin) Co., Ltd.
Branch Office Singapore
21, Bukit Batok Crescent,
Singapore 658065
Tel. +65-6846 1338
Fax +65-6846 9353
E-Mail: gezesea@geze.com.sg

France

GEZE France S.A.R.L.
ZAC de l'Orme Rond
RN 19
77170 Servon
Tel. +33-(0)1-606260-70
Fax +33-(0)1-606260-71
E-Mail: france.fr@geze.com

Tel.: 0049 7152 203-0
Fax.: 0049 7152 203-310
www.geze.com

Hungary

GEZE Hungary Kft.
Bartók Béla út 105-113.
Budapest
H-1115
Tel. +36 (1) 481 4670
Fax +36 (1) 481 4671
E-Mail: office-hungary@geze.com

Iberia

GEZE Iberia S.R.L.
Pol. Ind. El Pla
C/Comerc, 2-22, Nave 12
08980 Sant Feliu de Llobregat
(Barcelona)
Tel. +34(0)9-02194036
Fax +34(0)9-02194035
E-Mail: info@geze.es

India

GEZE India Private Ltd.
MF2 & 3, Guindy Industrial Estate
Ekkattuthangal
Chennai - 600 097
Tamilnadu
Tel. +91 (0) 44 30 61 69 00
Fax +91 (0) 44 30 61 69 01
E-Mail: office-india@geze.com

Italy

GEZE Italia Srl
Via Giotto, 4
20040 Cambiagio (MI)
Tel. +3902950695-11
Fax +3902950695-33
E-Mail: italia.it@geze.com

Italy

GEZE Engineering Roma Srl
Via Lucrezia Romana, 91
00178 Roma
Tel. +3906-7265311
Fax +3906-72653136
E-Mail: roma@geze.biz

Kazakhstan

GEZE Central Asia
050061, Almaty, Kazakhstan
Rayimbek ave. 348, A, office 310
Tel. +7 (0) 72 72 44 78 03
Fax +7 (0) 72 72 44 78 03
E-Mail: office-kazakhstan@geze.com

Poland

GEZE Polska Sp.z o.o.
ul. Annopol 21
03-236 Warszawa
Tel. +48 (0)22 440 4 440
Fax +48 (0)22 440 4 400
E-Mail: geze.pl@geze.com

Romania

GEZE Romania S.R.L.
IRIDE Business Park
Building nr. 10, level 2
Str. Dimitrie Pompei nr. 9-9a
RO-020335 Bucharest, sector 2
Tel. +40 (0) 316 201 257
Fax +40 (0) 316 201 258
E-Mail: office-romania@geze.com

Russian Federation

GEZE GmbH Representative
Office Russia
Kolodesnij pereulok3, str. 25
Office Nr. 5201-5203
107076 Moskau
Tel. +7 (0) 49 55 89 90 52
Fax +7 (0) 49 55 89 90 51
E-Mail: office-russia@geze.com

Scandinavia

GEZE Scandinavia AB
Mallslingan 10
Box 7060
18711 Täby, Sweden
Tel. +46(0)8-7323-400
Fax +46(0)8-7323-499
E-Mail: sverige.se@geze.com

Scandinavia

GEZE Norway
Industriveien 34 B
2072 Dal
Tel. +47(0)639-57200
Fax +47(0)639-57173
E-Mail: norge.se@geze.com

Scandinavia

GEZE Finland
Postbox 20
15871 Hollola
Tel. +358(0)10-4005100
Fax +358(0)10-4005120
E-Mail: finland.se@geze.com

Scandinavia

GEZE Denmark
Mærkærvej 13 J-K
2630 Taastrup
Tel. +45(0)46-323324
Fax +45(0)46-323326
E-Mail: danmark.se@geze.com

South Africa

DCLSA Distributors (Pty.) Ltd.
118 Richards Drive, Midrand,
Halfway House Ext. 111
P.O. Box 7934
Midrand 1685
Tel. +27(0)113158286
Fax +27(0)113158261
E-Mail: info@dclsa.co.za

Switzerland

GEZE Schweiz AG
Bodenackerstrasse 79
4657 Dulliken
Tel. +41-(0)62-2855400
Fax +41-(0)62-2855401
E-Mail: schweiz.ch@geze.com

Turkey

GEZE GmbH Türkiye - İstanbul
İrtibat Bürosu
Ataşehir Bulvarı, Ata 2/3
Plaza Kat: 9 D: 84 Ataşehir
Kadıköy / İstanbul
Tel. +90 (0) 21 64 55 43 15
Fax +90 (0) 21 64 55 82 15
E-Mail: office-turkey@geze.com

Ukraine

Repräsentanz GEZE GmbH Ukraine
ul. Viskoznaya, 17, building 93-B,
office 12
02094 Kiev
Tel. +38 (0) 44 49 97 725
Fax +38 (0) 44 49 97 725
E-Mail: office-ukraine@geze.com

United Arab Emirates/GCC

GEZE Middle East
P.O. Box 17903
Jebel Ali Free Zone
Dubai
Tel. +971(0)4-8833112
Fax +971(0)4-8833240
E-Mail: geze@emirates.net.ae

United Kingdom

GEZE UK Ltd.
Blenheim Way
Fradley Park
Lichfield
Staffordshire WS13 8SY
Tel. +44(0)1543443000
Fax +44(0)1543443001
E-Mail: info.uk@geze.com



141241-00

